

# TITAN ZZG 20

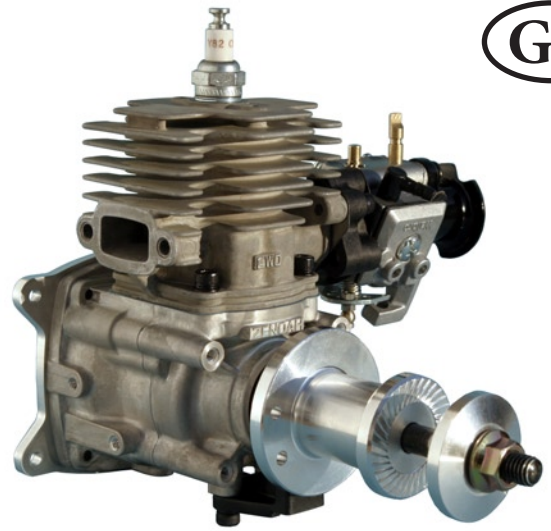

## Instructions

## Technical Data Titan ZG 20

Displacement:	20.1 cm <sup>3</sup>
Bore:	32.0 mm
Stroke:	25.0 mm
Power:	1,73 hp / 1,27 kW at 11.000 RPM
Torque:	1,23 Nm at 9000 RPM
Engine weight:	820 g
incl. engine mount:	850 g
and intake trumpet:	860 g
and ignition:	1040 g
and Silencer:	1185 g
Engine ready to fly including the 2450 mAh LiPo-battery order no. #2025:	1240 g

## 5 years guarantee for TITAN model aircraft engines

More than 20 years experience with TITAN engines plus our quality control allows us to extend the period of guarantee from one to five years. This guarantee covers the engine and the ignition only.

### The following conditions must be met to obtain the guarantee:

Guarantee is for the first owner only and is not transferable to any other person.

In the event of any claim, the engine must be returned to us with the original invoice. The serial number on the crankcase must be undamaged, and must not have been removed and reapplied. The serial number is registered by us with the buyers name and the date of purchase.

The only fuel to be used is the petrol oil mixture as specified in the instruction manual. Use of Methanol invalidates the guarantee.

The guarantee includes the Microprocessor Ignition unit, the maximum voltage of 4,8 Volts (4 cells NiCd or NIMH) must not be exceeded. Mechanical damage to the cables is not covered by the guarantee.

The guarantee is that we replace any defective parts free of all labour and material costs and pay only the return postage and packing. This guarantee covers only the engine and can in no way be construed to cover anything else.

This guarantee does not cover crash and related damage in any form whatsoever.

## **Congratulations on your purchase of a Titan ZG 20**

About the biggest problem facing man is that he does not know what he does not know. To resolve this problem requires enormous efforts, however try to avoid so much as possible unnecessary mistakes and please read the following pages carefully. Do not take fright at the amount written here, it is really a list of mistakes many modellers have made and you should at all costs avoid. A reliable running engine stands or falls with the way you instal the engine in your model, and how you handle your engine. It is up to you, to read and carry out these instructions, to have success and be able to get real fun out of the hobby of flying model planes.

Hand starting the ZG 20 with the Microprocessor Ignition is child's play. The starting technique with this ZG 20 is very different from that of the magneto ignition Zenoah engines, so please follow the starting instructions and forget what you have learnt with the magneto ignition engines.

The Titan ZG 20 is in no way complicated, it is very robust. To ensure your engine reaches you in perfect condition, we have specially trained people to completely strip each engine down and thoroughly check it. This stripping and reassembling takes between 25 and 30 minutes per engine and ensures that you receive an engine that is mechanically sound as can be.

The Titan ZG 20 is a very powerful engine, the thrust from the propeller is such that you simply cannot afford to take any chances. You take a chance and you run the risk of not only endangering yourself, but other people as well. Take care before each start, double check to see the throttle is not on full power. If you do not have anyone to help, you must anchor your model securely or flick the propeller over from behind the engine, using the other hand to hold the model, this way you are in no danger from the prop. A screwdriver stuck in the ground in front of each wheel is not only useless, it is dangerous!

Do not taxi your model right back to the starting place on your flying field, instead cut the engine and push the model back! Pushing your model back, you may think seems unprofessional. Forget such ideas! You never know, something might go wrong and your model suddenly has full throttle! Should the result be that you have reduced your club chairman's model to its component parts, you can count yourself lucky if it's not the chairman himself, or his dog.

## Engine Assembly

Please assemble the carburettor and the silencer according to the drawing below.

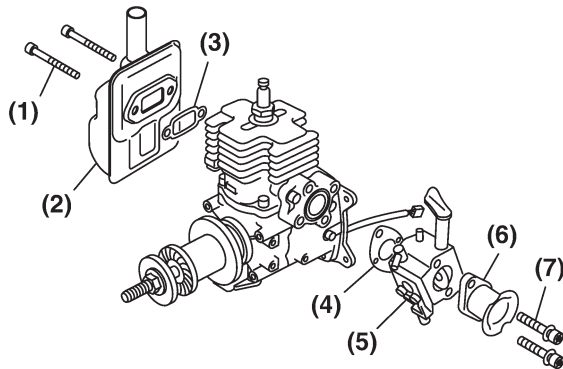

No.	Description	Qty.	Tightening torque
1	Silencer screws	2	8,8 Nm
2	Silencer	1	
3	Exhaust gasket	1	
4	Carburettor gasket	1	
5	Carburettor	1	
6	Intake trumpet	1	
7	Carburettor screws	2	3,4 Nm

The carburettor can be fitted in 90 degree steps, you can chose anyone of the four positions to suit your model.

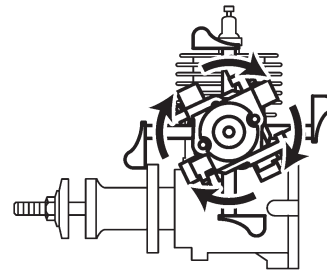

## Engine Installation

Due to the back plate the ZG 20 is very simple to instal. Use socket head screws, spring washers and crown nuts on a 6 mm plywood firewall. The firewall can be reduced in thickness if it is only slightly larger than the back plate. There is a screw hole pattern on the last page.



*The Titan ZG 20 with standard silencer installed in a 1,65 m ARF Velox Rev II from "The World Models".*

The engine can be mounted on D-Locks. Whether a rigid or soft mounted engine causes more noise depends, very largely on the covering of the fuselage, a very taut silk or nylon and also various plastic film coverings are not ideal, as this acts as a drum skin.

## TITAN ZG 20 Scale 1:4

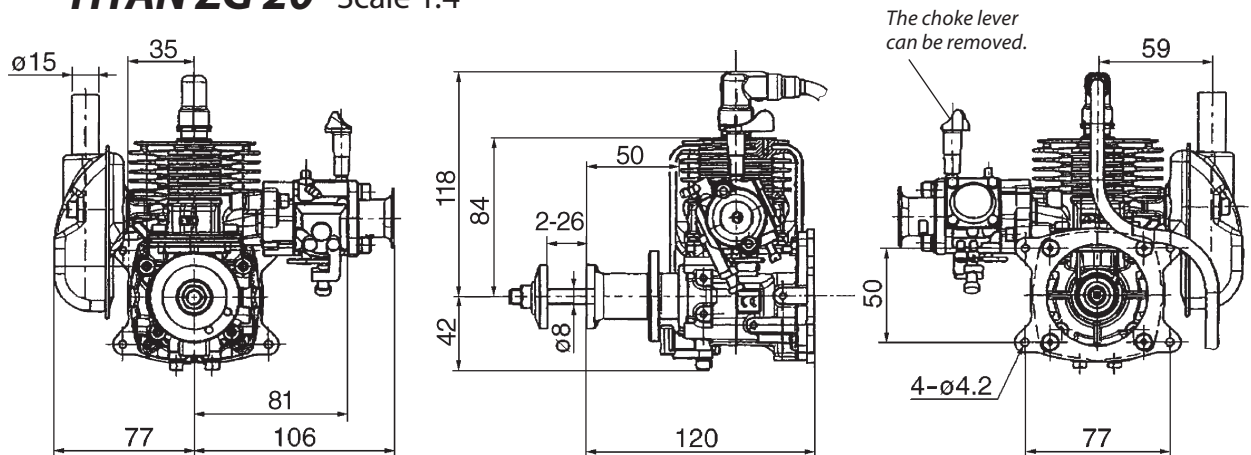

A properly constructed model can absolutely withstand the vibrations levels produced by the ZG 20. The receiver is best fitted inside a balsa box surrounded with plastic foam. Never fit the receiver with Klett band or rubber bands to a board. Chose good quality larger vibration resistant servos with the best potentiometer and motors.

### Engine Cooling

For cooling the Titan ZG 20 it is not necessary to have a specially large opening in the cowl. But it is essential to ensure, that as much air as possible entering the cowl flows through the finning and around the carburettor, which also needs cold air. Air takes the path of least resistance and will not normally flow through the fins, unless you take positive steps to force it to do so by means of air-ducting. Balsa sheeting and blocks is the best material to use for this. A motor in a large volume cowl, with large air inlets and no form of ducting, is a very poorly cooled engine!

It is essential that the ducting almost makes contact with the engine, so balsa is better than aluminium, for should the latter make contact with the engine, this can easily cause severe radio interference due to metal to metal contact generated noise.

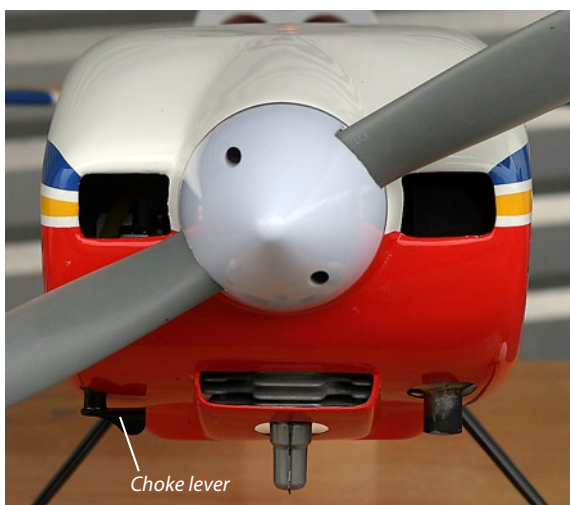

*Apart from the plug cap, the ZG 20 fits perfectly under the Velox engine cowl. The rather small inlet opening is large enough due to the ideal position it has. The intake trumpet is not fitted, in the interest of quietness, there is no hole in the cowl for the carburettor intake. With all possible aerobatics and speeds the ZG20 runs perfectly. It would appear the relationship between inlet and outlet areas are perfectly matched on this model.*

## Installing the ignition unit

The most important rule covering battery ignition systems first:

- ⚠ **Never ever switch on the ignition without the spark plug cap being firmly on the spark plug!**
- ⚠ **All components of the ignition as well as the ignition battery must be as far removed as possible from the receiver. Minimum distance being 15 centimetres!**

The microprocessor ignition is completely encapsulated and extremely robust. We fit a mounting base with four screw holes so this can be fixed with screws. There is a screw hole pattern on the last page.

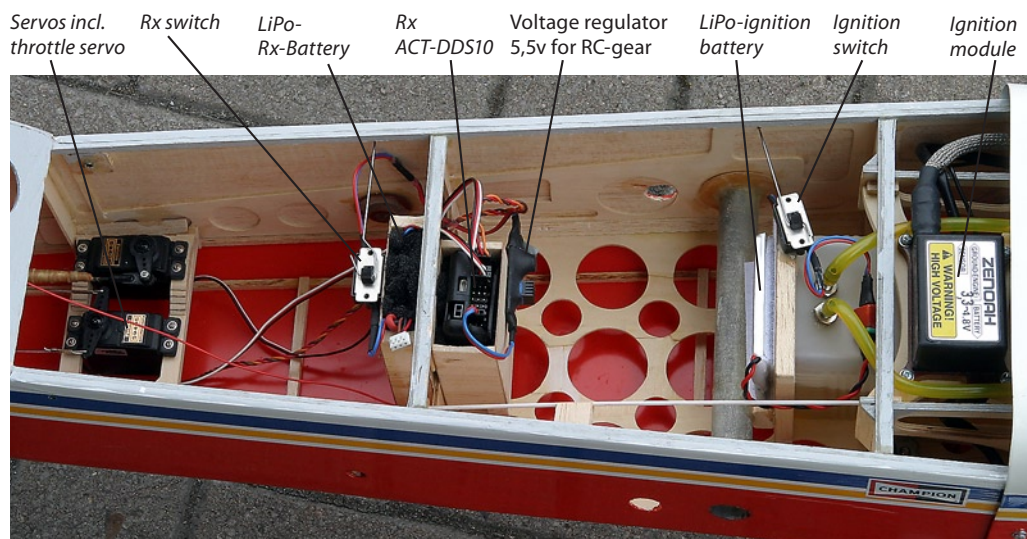

Please fit the cables very carefully into your model, especially the high tension cable, as this will not contain the 21,000 volts if it is damaged due to scuffing against the cowl inner surface. If the screening flex is damaged due to scuffing when threaded through a GRP cowl opening, it will not be long before the inner insulation is damaged also. Then the HT will short out to the screening flex and this may cause massive radio interference and will of course lead to an ignition cutout.

**Mechanical damage caused to the HT cable is not covered by the guarantee!**

## Switch

You need a knife edge type of switch such as is used for radio gear. A Robbe/Futaba switch harness can be used on the power supply for the ignition module. Toggle switches with roller contacts are not suitable as these are intended for 240 V. Used on 4 Volt oxidation can occur, this increases the contact resistance and will lead to ignition failure.



**⚠ You must be sure that the polarity is correct when connecting the battery. Incorrect polarity will permanently damage the ignition module!**

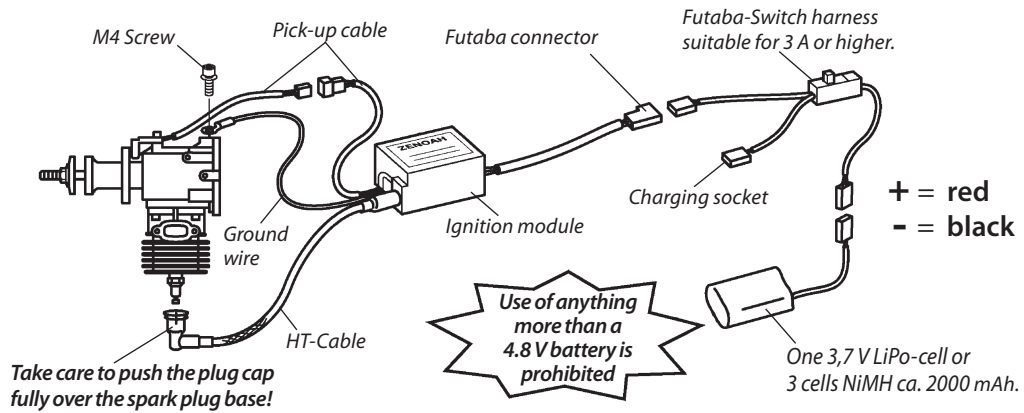

### Ignition Battery

The ideal battery is a single 3,7 V LiPo cell of 2000 to 2,500 mAh capacity. E.g. our ZG-I 2450 Li-Polymer Ignition Battery, order no. #2025. It only weighs 54 grams including the connector and supplies energy for one and a half hours flying. If you still think the LiPo's are too dangerous, then you can use 3 (three not four!) cell NiMH with about 2,000 mAh.

The ignition module is designed to work at up to 20.000 RPM for use on the marine version of the ZG 20. For this, the battery has to be a 4 cell NiCd or NiMH. Used in model aeroplanes, the ignition performs perfectly and without a stutter down to 3.1 Volt, as we need only a maximum of 12,000 RPM. The lower voltage reduces the otherwise very high power consumption to a reasonable level and the ignition module temperature will be lower.

At 3.0 Volt, when the battery is almost empty, the engine will stutter for a few seconds and will stop running all by itself. The current is then reduced to only 45 mA and you will be forced to land the model. This is a perfect protection for the LiPo Battery. It is obvious that for the safety of your model, it is better not to fly that long, as you might not be able to reach the flying field!

Current consumption at:	3,7 V	4,8 V
2000 RPM	1,1 A	1,4 A
From 4500 RPM to max. RPM	1,6 A	2,2 A
Idle current (propeller standing still)	45 mA	55 mA

If the ignition module is used with 4,8 Volts, depending on the surroundings, the module can reach 80 degrees C. This is normal and will not cause any damage.

**⚠ Do not pack the ignition module in plastic foam and do not handle when hot.**

### Spark plug

The ZG 20 is supplied with a Champion Y82. Correct gap is 0,5 mm. Use no other type of plug. The NGK CM6 may look similar from the outside but is completely different!!!

## Fuel Tank

With a 500 cc tank the Titan ZG 20 will run at full throttle for about 25 minutes. A 250 cc tank for an aerobatic model will have ample duration.

The felt clunk filter has two important roles i.e. to overcome fuel foaming and to filter out any foreign particles. Always use the cotton felt clunk filter #0060 and no other type.

The clunk filter will suck the smallest amount of petrol out of the tank. Omit this felt clunk filter and your engine will draw more air than fuel. Automotive filters and filters sold for glow plug engines are useless.

Fitting a T-piece in the fuel line between the tank and carburettor for tanking will be an obvious mistake to most folks, but we have seen this method of short-circuiting the felt clunk filter in the tank, with the obvious results, more often than one would imagine.

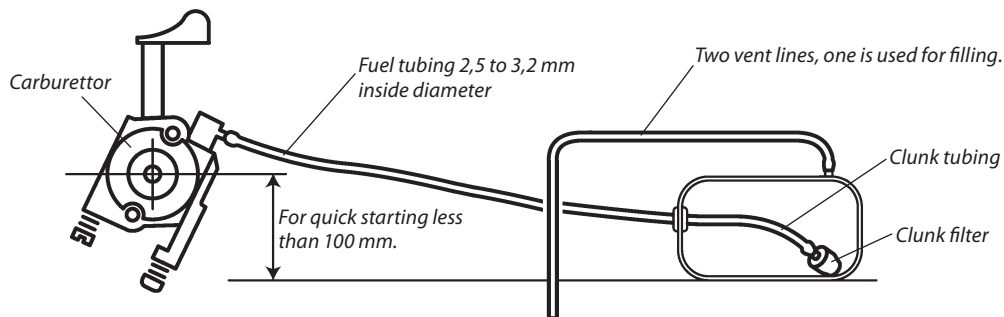

It is better to place the tank rather higher than the carburettor. Petrol will not run out of the carburettor due to the non return valves integrated in the Walbro carburettor. With the tank being higher, the fuel line is filled much quicker. The length of the fuel line is not critical, this enables one to install the tank at the CG or in any other position. The fuel line should be straight and not a switchback, as this may cause air entrapment in the high places.

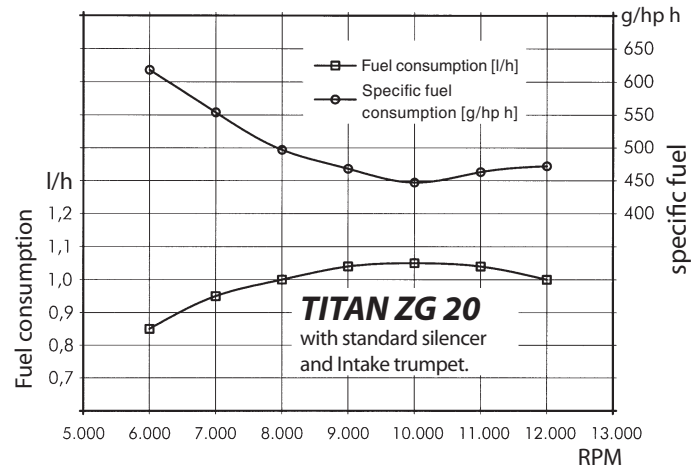



## Tank Nipples

The double sided tank nipple from the clunk filter is best placed in the middle of the tank cap. The single sided nipples are fitted in the middle and at the rear end as shown in the photograph. These two air vent lines must be led forward over the tank and then down into the fuselage floor at the cooling air outlet of the engine cowling. Because the two vent lines are at the rear, there will always be a little air trapped in



the top of the fuel tank with a taildragger model. The model then can be turned upside down or stood on it's nose, or with the nose vertically upwards and the fuel cannot run out.

One of these vent lines (does not matter which) is used to fill the tank. For flying or otherwise the two vent lines are partly shut off with two short pieces of fuel tubing that have inserted a 3,5 mm self tapping screw about 15 mm long with the head broken off. Due to the screws coarse thread, enough air can be sucked into the tank, but even during violent stunting no fuel will be lost. The saving in fuel is considerable! This system is simple, well tried and 100% reliable. There is the added advantage, that by filling the tank from the bottom of the fuselage, petrol spilled does not run over the model.

## It is best to leave a little fuel in the tank at all times

Even when the model is in your home or workshop, it is better not to empty the tank. The remaining fuel will prevent the carburettor diaphragms from drying out and becoming hard. Partially empty the tank only when really necessary, i.e. when the tank is full. To partly empty the tank, just turn the model onto it's back. As long as the self tapping screws are inserted, no pressure can build up in the tank. But with the two vents fully closed, petrol will be forced into the carburettor with an increase of vapour pressure, due to the higher temperature in a dwelling house. The smell of petrol is then unavoidable

## Fuel Tubing

 **Silicone tubing cannot be used for petrol** as this is almost destroyed after coming into contact with the fuel. Same with clear PVC tubing, PVC slightly expands, gets hard and will become loose on the nipples, allowing air to enter the petrol with vibration.

Our specially made, thick-wall **Neoprene fuel tubing** is fairly soft and can be sealed perfectly at the nipples with 0.5 mm copper or brass wire, by being wound twice around the tubing and twisted together. Do not be tempted to use nylon tie straps or small Jubilee clips to seal the fuel lines, these straps and clips do not exert pressure right around the tubing, they only serve to pull the tubing into an oval shape on a round nipple. The black fuel tube is very tough and due to having a thick wall, it is not easily kinked.

A good alternative tube is the transparent yellow **Tygon® F-4040** tubing. It is much lighter and does not expand in contact with petrol, also you can see air bubbles in the fuel. You must use more care in laying this Tygon® tube in the model to ensure that there are no sharp bends. This tube is not especially heat resistant, therefore it must not make contact with any hot engine parts.

## Fuel

For fuel, you can use normal grade un leaded petrol mixed with a two stroke oil with a ratio of 1:40, but for running in use a larger amount of oil, at a ratio of 1:30 for the first five litres.

The best two stroke oil you can buy is BEL RAY H1R. Using this oil, you can run your ZG 20 with a ratio of 1:50. For running-in use 1:40 for the first 5 litres. The BEL RAY racing oil has a tenfold better lubrication characteristic than mineral oils, achieves more power with minimal carbon build up and has a superb corrosion protection.

**TAKE GREAT CARE WHEN HANDLING PETROL:**

**USE ONLY THE SPECIAL AIRTIGHT RESERVE CANISTERS**

**NO SMOKING!**

## Throttle arm linkage

For your own interest neither remove or unclip the throttle return spring. This spring will stop the butterfly valve hammering against the carburettor body causing excessive air leakage. The spring also serves to take up the play in the throttle linkage and should the throttle linkage fail, the spring will shut the engine down - a safety factor that should not be discarded! The low loading on the throttle servo caused by the spring is no way comparable to the loading on a servo for the control surfaces due to air loads and vibration.

There is a small Tufnol CNC milled throttle lever supplied with the engine, you can glue this to the butterfly valve shaft with Araldite 2011 epoxy to best suit your throttle linkage. You can use either a short metal rod or a piece of Bowden cable.

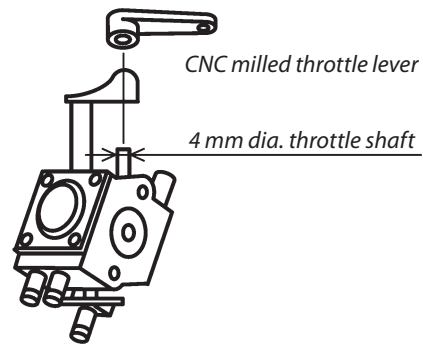

A Bowden cable between the servo and throttle lever has to be connected in such a way, that the return spring causes the throttle lever to press against the Bowden cable and not pull on it! Let me explain why this is so important: Engine vibration induces swinging of the cable, if the Bowden cable is installed with a bend, as it is often the case. This swinging wants to throw the cable outwards, similar to a skipping rope. If the return spring on the throttle lever pulls the cable inwards against this movement, it can cause the tickover speed to fluctuate. On higher rpm there will be almost no swing and the spring is able to keep the cable inwards, but on lower rpm the cable may get into resonance and the swinging becomes stronger and will throw the cable outwards. This raises the RPM, as the cable now pulls on the throttle lever and opens the throttle. To compensate for this, you will be forced to throttle the engine down even more. At lets say 2000 rpm the cable will fall out of resonance and the spring will gain the upper hand again, closing the throttle completely and causing the engine to stop immediately.

When the servo is pushing against the spring, the centrifugal force and the spring are working in the same direction, the engine will then react smoothly and accurately to the throttle stick - always and at every RPM!

Never remove the butterfly valve from the throttle lever shaft! For safety, Walbro has spread the end of the small screw, so that removing this screw damages the threaded hole beyond repair, and re fixing the butterfly valve safely is practically impossible. Either the shaft breaks and the screw comes loose, or the loose-fitting screw drops out and is sucked into the engine, with the result you have a heap of scrap on your hands.

The **choke** can also be operated by a servo. For this purpose there is a second lever arm with a rather larger hole for the shaft, this lever arm can be epoxied with Araldite 2011 to the choke lever shaft. The black manual lever can be simply pulled off. Do not attempt to remove the choke ball lock. A standard servo will overcome the small amount of resistance without difficulty. With a mini servo set the servo throw on maximum e.g. 150% and use a small servo arm.

## Propellers

An excellent propeller for the Titan ZG 20 is the APC N 17x8" or alternatively the APC 16x8". Should there not be enough ground clearance, you can use the APC 15x10". The APC propellers are very efficient and extremely quiet. Used carefully, these sizes will withstand high RPM.

The Menz propellers 15x8", 16x6" and 16x8", although certainly louder and with less thrust, are a cost efficient alternative especially for simpler models.

Those who prefer carbon fibre propellers can use the Super Silence two blade 15x11", 16x8" Pro or 16x10". A suitable three blade is the 15x11" Super Silence.

You must balance every propeller. Some manufacturers claim they balance their props, you should check this claim, as their definition for "balanced" may not coincide with what yours should be!

**⚠ WARNING:** When using props made from thermoplastic such as Nylon or Polyamide, you must realize the real danger of a blade being shed which can happen any time, even when the props are glass or carbon fibre filled. The stress limit of these propellers can be exceeded due to material fatigue, drying out, production faults or mechanically over stressing during ground contact on bad landings.

Propeller	RPM
APC 15x8"	8900
APC 15x10"	8300
APC 16x8"	8300
APC N17x8"	7700

The RPM increases in flight by 2,000 RPM. Larger props are more efficient, therefore the APC N 17x8" is superior to the APC 15x8" even when at first glance on the performance graphs this appears otherwise.

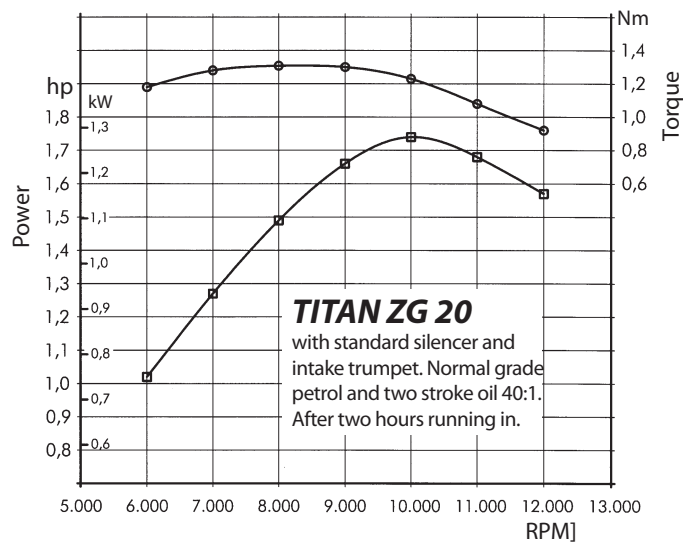

## Propeller fixing

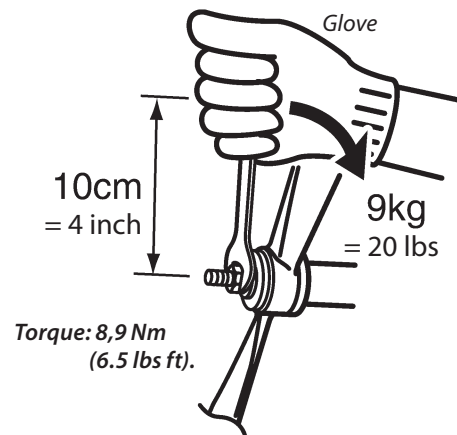

Use the supplied spanner to fix the propeller and try to tighten down to 9 kg. Do not over tighten as the shaft is only M6 where it is screwed directly into the crankshaft. It will shear if you use too much force.

Fixing the propeller with a central nut and a large area hub has proved to be a safe and extremely reliable method, proved over many years. As long as the propeller nut is correctly tightened, it is impossible for the propeller to loosen.

Should the propeller loosen when flicked over, nothing drastic will happen. The propeller may have been compressed with the pressure from the nut, this means you have possibly forgotten to check the nut for tightness occasionally.

It is a different story where propellers are fixed with six screws. This system can be dangerous, the screws loosen and you can still flick the prop over, but in flight, due to the firing stroke and the inertia of the prop the screws are bent backwards and forwards until they all shear, the prop flies off like a boomerang and can cause a lot of damage to the soft human structure that covers our bones. During flight, the propeller nut will not loosen, every firing stroke in effect tightens the propeller nut.

Please do not fit a steel dowel into the propeller hub. The dowel allows you to turn the propeller when the nut is loose. The first indication you will get is the wood propeller will split in half and fly off ...can cause a nasty wound.

If you fit a spinner and there is not enough friction between the aluminium spinner back plate and the prop hub, simply cut a disc from 320 grit sanding paper and fit the grit side against the spinner back plate.

## Carburettor setup

The two jet needles are side by side with the letter H and L moulded in the carburettor body. **H= high speed needle. L= low speed needle.**

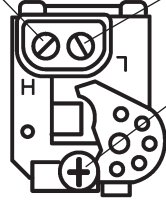

The large nickel plated **tickover stop screw** is useful for running your engine on the test rig, but in the model it is better removed so that one can stop the engine using the throttle servo.

Basic needle settings	H	L
with silencer and intake trumpet	1 1/2 turns	1 1/8 turns

The two needle settings depend on the propeller size. Adjusting the low speed needle must be very carefully done. For a low RPM tickover it must be on the lean side, for a good acceleration it must be on the rich side. With care a compromise can be found. The acceleration will be improved with the intake trumpet and/or a smaller propeller. A slow acting throttle servo is best, do not slam the throttle open on the test rig, just advance it smoothly.

If you use the engine without the intake trumpet both needles have to be opened slightly more and the fuel consumption increases.

The longer the intake trumpet the better the engine turns larger props. Instead of the supplied intake trumpet our aluminium intake trumpet #0800 can be substituted for this.

The optimum adjustment of the two needles is best done by flying the model and checking the spark plug colour when the plug is still hot after a fairly long stretch with full throttle, then landing the model and immediately checking the spark plug colour, the colour should be a light brown or possibly grey. The engines should not be allowed to run at tickover before this test, if the low speed is too rich then the spark plug will be black and oily, if the low speed is too lean then the plug will have a white or glassy appearance.

If the intake trumpet projects out of the cowl, and the engine runs rich in level flight or diving, but on the ground or climbing runs normally, this is due to a buildup of air pressure in the cowl. This pressure increase affects the carburettor through the small hole in the steel four-screw cover, causing the diaphragm to be depressed, which increases the fuel feed to the low speed and main jets.

The answer to this problem is simple. Solder or glue with Araldite 2011 a piece of brass tube onto the hole. This tube must reach exactly to the end of the intake trumpet. You will of course remove the cover before soldering. With the brass tube in place, the air



pressure is now measured outside of the cowl at the Carburettor air intake. If this does not solve the problem then the cause is with the shape of the cowl and the position of the intake trumpet in the cowl.

## Silencer

The supplied silencer is very good in comparison with larger engines or to some glow plug types.

Tighten down the screws after the first flight with the screws still being hot.

The various headers and stainless silencers for the ZG 23SL and ZG 26SC also fit the Titan ZG 20.

We were amazed at the phenomenal power increase by fitting the high performance silencer #2593. The power increase is 40% above the standard supplied silencer. So fitted is the ZG 20 very quiet and has a very pleasant sound. Acceleration is constant right through the throttle range, and also the mid throttle position is excellent. The complete silencer system, including the „S“ form stainless Funtana header #2571, and the Teflon tube and spring clamps, weighs just 150 grams more than the standard silencer. We found the best prop for 3D flying with the Silencer #2593 is the CF-Super Silence 18x8" Pro #9970.

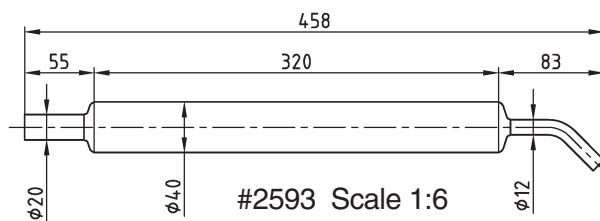

Propeller	RPM measured on an new ZG20 fitted with the stainless high performance silencer #2593 / header lenght
APC 15x8"	9850 1/min / 23 cm
APC 16x8"	9400 1/min / 23 cm
APC 17x8"N	8200 1/min / 26 cm
Menz S 16x8"	8500 1/min / 23 cm
Menz S 18x6"	8000 1/min / 26 cm
Super Silence 18x8"Pro	8200 1/min / 26 cm

## Starting the engine

If you have had no previous experience with large volume engines then use a thick glove or a chicken stick (garden hose over a piece of dowel) for starting.

Due to the Microprocessor battery ignition starting the engine is very easy. Although the starting method is entirely different to what you are possibly used to with the magneto ignition.

### One important point to begin:

**Never prime the engine by sucking in with a switched off ignition!  
The battery ignition, unlike the magneto ignition, will not start the engine with a wet plug.**

### For starting follow these rules exactly:

1. Fill the tank (very helpful).
2. Close the choke.
3. Set the throttle at a slightly higher setting than normal tickover.
4. Have someone hold the model.
5. **Switch on the ignition.**
6. Immediately hit the prop **without any prior sucking in.**
7. The engine will start as soon as enough fuel air mix is ingested due to the closed choke, and will turn a couple of times and stop as the choke is not opened. This is nothing for concern, the engine has shown you there is enough fuel ingested. It remains to open the choke and with a couple of flicks the engine will fire, burn off the excess fuel and run.
8. Let the engine warm up for about 15 seconds before advancing the throttle.

It is to no purpose to violently flick the propeller, **just lightly flick the prop over the TDC**, you will notice it only takes the small finger at the propeller tip to do this. An elegant method is to flick the propeller over from behind the engine, using the other hand to hold the model, this way you are in no danger from the prop. You will find it pays to have the transmitter in range from your flicking hand.

If you manage to flood the engine, you must remove the spark plug and dry it. As a big difference to the magneto ignition, the battery ignition cannot fire a really wet plug!

As soon as you have landed turn off the ignition: This will avoid anyone turning the propeller unintentionally and thereby starting the engine. Apart from this, the idle current will slowly drain the battery, even when the engine is not running.



**The ignition must be shut off at all times when not used for flying!**

## Adjusting the pick up for very light models

You can turn the sensor to the right by a couple of degrees. The engine will run smoother and slower at tickover, but at the price of a loss of some 100 RPM at full throttle. This set up is recommended for very light models.

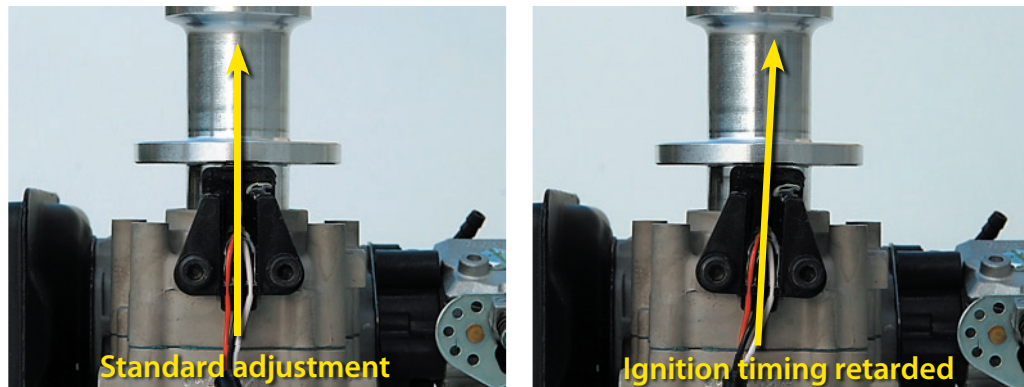

## Running in the engine

This is the critical time in an engine's life. Do not use the glow-engines method of a really rich set needle valve on a test stand on half power, rather set the needles on the Titan ZG 20 to a normal position and **fly** the new engine with very short periods of full throttle and long periods of tickover. You will of course ensure that the mixture setting is not on the lean side. Avoid letting the engine run at half or three quarter throttle for long periods. After the first tank full you can increase gradually the full throttle periods. After five tank fulls you can fly full throttle for as long as you wish.

Experience has shown the power steadily increases over the first thirty flights, and even after this time, the power will increase from season to season, due to the build-up of carbon deposits on the piston crown and on the combustion chamber walls. This carbon build-up increases the compression ratio. Because the engine is designed for an extraordinary long life span, even when mineral based two stroke oils are used, the designers had chosen a relatively low compression ratio to allow for a considerable amount of carbon build-up. So "don't worry" about carbon build-up and as long as it is not in the piston ring groove, do not remove it, instead "be happy" about the extra power!

It is far better to break in the engine in a model with the engine cowling fitted. Due to the unequal temperature distribution around the cylinder, because of the unequal cooling airflow, the cylinder always tends to slightly distort. A new piston ring, with his special surface treatment, can easily adjust to this condition. During the first hour of running in, the piston ring will continually get polished and thereby it's surface becomes harder. An engine, that has been run in on the test stand, must run for a considerable longer length of time, until it has settled down to the new and almost always completely different temperature distribution under the models engine cowling.

**Very important:**

**Although the microprocessor ignition is screened, please make a range test with full throttle before the first flight. Use a small propeller to simulate the RPM when the model is in the air.** The range difference with the engine shut off and running at full throttle should be only small.

**When using a PCM-radio, use the fail-safe and set it so that in the event of interference the engine will be throttled to a reliable tickover. If you can programme the time lapse, then make this half a second.**

By the way, it is technically impossible to shut off the fail-safe with a PCM-radio, it is an integral component of the PCM-system, that cannot be removed. Should the fail-safe be activated by interference or a loss of range, you have several pre-programmable options. This means you can programme the radio as to what will happen, for example the length of time elapse, usually from 0,25 up to 1 second, during which the servos will stay in the last correctly received position before they move to your programmed „fail-safe position“. With fail-safe on or off, you get full control again in the moment the receiver gets a good signal. With the fail-safe „shut off“ the servos stay at the last correctly received positions and will stay there until either the model crashes or the receiver once more has a satisfactory signal from your Tx. With the engine throttled by the fail-safe, the signal will often get better and you have a reasonable chance. Also you usually have some prior warning when something is not quite right.

Imagine when your model is taking off, someone switches on his Tx on your frequency. Your model is heading in the direction of bystanders at full power. You would be greatly relieved if your PCM-radio immediately switches the engine to idle. Or?

If you use the metal throttle lever already on the carburettor and a metal pushrod for your throttle, you must insulate this metal pushrod from the engine with a nylon ball joint.

**Install the receiver, battery and servos as far away as possible from the engine and particularly from the microprocessor ignition unit and ignition battery;** in certain cases the interference comes not through the aerial, but through the wiring from the batteries or the servos. A double superhet will not help!!! Most cases of interference are not caused by the ignition, but through metal to metal generated noise or from a servo pot wiper that has suddenly become faulty.

**Receiver aerial**

In many radio instructions it states, that one should lay the aerial in a straight line. This is only OK when the Rx aerial is parallel to the Tx aerial and not pointing directly to the Tx as is mainly the case in take off and landing. When the Rx aerial points directly at the Tx this causes the reception to drop to its lowest value. The answer is simple: lay the aerial straight in the fuselage but bend up the last 25 cm to form a right angle and fix the aerial in this position securely. You can of course have this 25 centimetre vertical element straight out of the Rx case and the rest laid flat along the fuselage. If your fuselage is short, then you can have this vertical element along the fins king post. A vertical piano wire aerial on a model owes its better performance to being bent over with the airstream.

The best solution is the ultra modern double receiver system "DDS 10" from "ACT europe". Here the aerials are laid in a straight line 90 degrees to each other and any attitude of the model has no noticeable effect on the range.

## Maintenance

The Titan ZG 20 requires almost no servicing. The Walbro carburettors are superbly reliable and never give trouble when left alone. Never use compressed air anywhere on your carburettor or it will never be of any use afterwards. Never remove the fine stainless steel gauze filter in the carburettor for any reason. When you have followed our advice and fitted a cotton felt clunk filter, there will never be any dirt in the carburettor, but there may well be fine cotton fibres over the small gauze filter (this is the sole reason for this filter). Every five years or so, you can remove these fibres carefully with a toothpick, or tweezers.

Be careful adjusting the two needles, when screwing in these needles go very carefully to find the null point, so soon as you feel the first sign of resistance stop immediately, if you screw these needles in with force you will widen the hole in the body and then your carburettor is scrap. If your engine suddenly decides not to start never try adjusting the two needles they just cannot help you, the cause of the problem always lays somewhere else.

If your engine is difficult to start after the hibernation, suck fresh petrol into the carb to loosen the thick oil left after the petrol has evaporated, and let this stand for a few days and you will find the engine will run again without any adjustment of the needle valves.

Those who may wish to control the tightness of the fixing screws should note the torque loading in the following table. Absolutely critical are the four cylinder fixing screws. These screws must never be really tightened down as the gasket between the cylinder and crankcase will be squeezed out rather like toothpaste and the corners of the cylinder flange will be forced downwards. This will distort the cylinder and you will notice that when the engine is hot the piston will have the tendency to hang up at BTD, the engine will not have a good tickover and power will be down in full throttle and the cylinder can be thrown in the dustbin. This can easily happen to modellers who make a habit of really tightening down screws on new engines just to make sure. If you do not possess a torque meter or you have no feel for tightening screws, then please leave the cylinder screws alone.

	Thread	Tightening torque
Spark plug	M10x1	7,8 Nm (6 lbs ft) *
Cylinder fixing screws	M4	3,9 Nm (3 lbs ft)
Crankcase fixing screws	M4	3,9 Nm (3 lbs ft)
Silencer fixing screws	M5	8,5 Nm (6,5 lbs ft)
Carburettor insulator screws	M4	3,4 Nm (2,5 lbs ft)
Carburettor screws	M5	3,4 Nm (2,5 lbs ft)
Propeller nut	M8	8,9 Nm (6,5 lbs ft) *
Motor mounting plate	M4	2,0 Nm (1,5 lbs ft)

\* use the spanner delivered with the engine package

Thank you for taking the trouble to read carefully what I have written here. Have fun with your Titan ZG 20.

Gerhard Reinsch,

English translation by Toni Clark.

August 2006



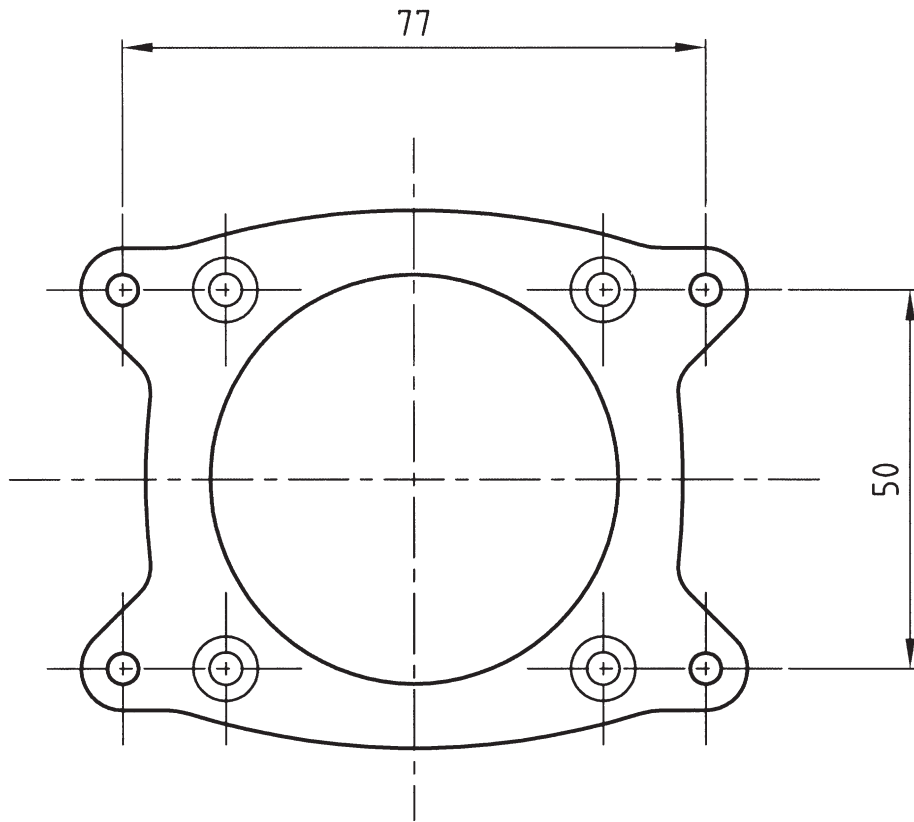

Drilling pattern for engine mount

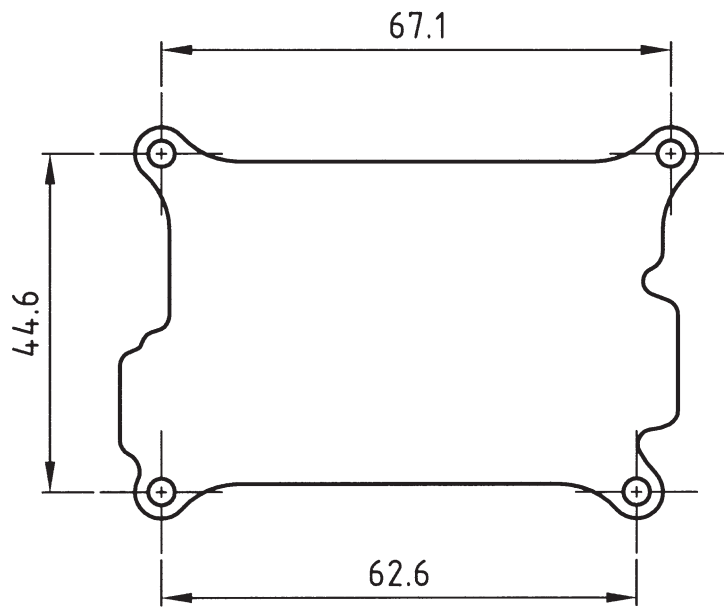

Drilling pattern for ignition module

